

Mechanical Features



Terminal Box Position acc. to EN 12157

In accordance with EN 12157 the terminal box is positioned above the outlet on immersion and suction pumps:
Position 1 is the standard design for immersion pumps, position 2 for suction pumps, and position 3 for miniature centrifugal pumps.
If a non-standard position is required, please provide details when ordering.

	Position	Motor top view
1		Terminal box opposite to pump discharge. Standard set-up for immersion pumps.
2		Terminal box to the left of the pump discharge. Standard set-up for suction pumps. For Horizontal End-Suction pumps please refer to page 16.
3		Terminal box over the pump discharge. Standard set-up for miniature centrifugal pumps.
4		Terminal box on the right of the pump discharge.

Lacquering

Standard	RAL 9005
Upon request	Other colors and unpainted or primed available on request.

Mechanical Features



Horizontal End-Suction Pumps – Terminal box and foot location

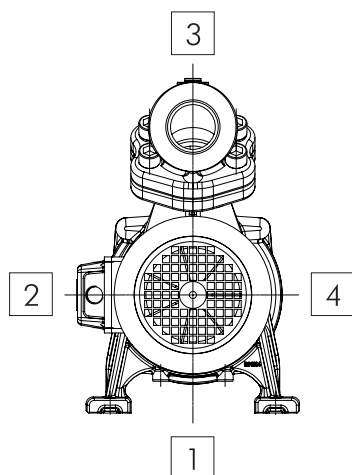

Location	Series SBA, SBG and SBF	
	Terminal box location	Foot location
1	–	Standard
2	Standard	●
3	□	–
4	●	●

- available
- available upon request
- not available

Attention:
Terminal box location and foot location cannot be facing in the same direction!

Horizontal End-Suction Pumps – Suction port

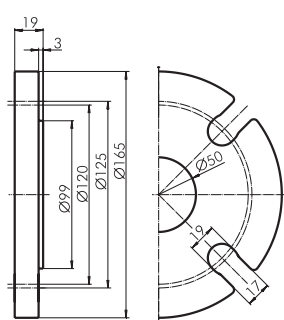

DN50, 4 hole flange connection
size 140

DN50, 4 hole flange connection,
is equivalent to ASME B16.1-
2005 Class 25 Flange NPS 2 and
JIS B 2239:2004 10K A50

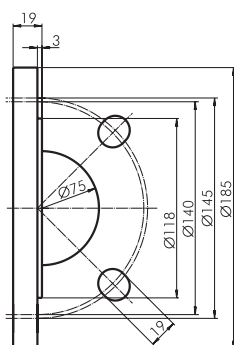

DN65, 4 hole flange connection
sizes 400, 550, 600
sizes 650, 850, 1150, 800, 900,
1300

DN65, 4 hole flange connection,
is equivalent to ASME B16.1-
2005 Class 25 Flange NPS 2 1/2
and JIS B 2239:2004 10K A65

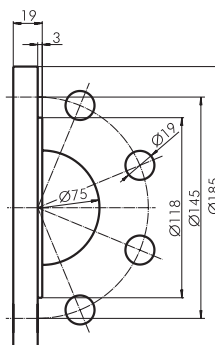

DN65, 8 hole flange connection
sizes 850, 1150, 1100, 1300
Available upon request

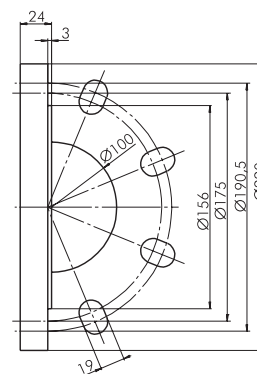

DN100, 8 hole flange connection
sizes 1350, 1550, 1850
sizes 1600, 1700, 2000

Dry-running Version (-GD)

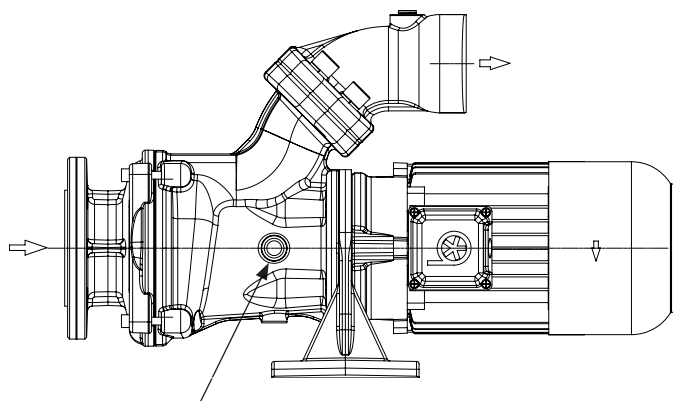

Monitoring window for models
with second mechanical seal (-GD)

For single-stage pumps, a second mechanical seal is available for unlimited dry-running. By utilizing an additional oil reservoir, continuous lubrication of the mechanical seal can be assured, which in turn allows dry-running of the pump.

The oil level within the reservoir can be monitored through an integrated monitoring window.



Brinkmann Pumps with SAE flanges or 45 degree flanges

Most Brinkmann pumps with motors larger than 0.5 kW are equipped with the user friendly SAE flange or 45 degree flange connection which allows for either vertical or horizontal pipe connection. Each SAE flange or 45 degree flange is equipped with an additional G 1/4 pressure gauge connection.

For optimized chip transport and to avoid chip blockages inside the pumps, all flow is directed in long soft turns. All flanges are designed in a way that any cross section diameter changes down stream are always increasing never decreasing in order to prevent bottle necks inside the pump.

Small pump body (Ø 140 mm)

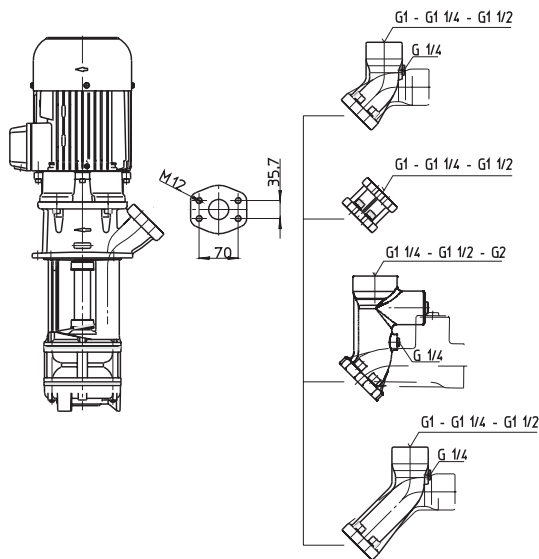

SAE flange G1, G1 1/4, G1 1/2, G2

Standard as shown on data sheets. Fully interchangeable. Upon request also available for TC and TH pumps.

SAE Extension Port

This extension port is available upon request for all pumps which are featuring an SAE flange.

Regulating Valve for SAE flange G1, G1 1/4, G1 1/2, G2

This regulating valve allows to adjust the flow rate of the pump even during regular operation. This valve has no complete shut off function. An additional check valve is available upon request.

SAE flange G1, G1 1/4, G1 1/2, G2

Standard for motors larger than 11 kW and for standard motors.

Large pump body (≥ Ø 200 mm)

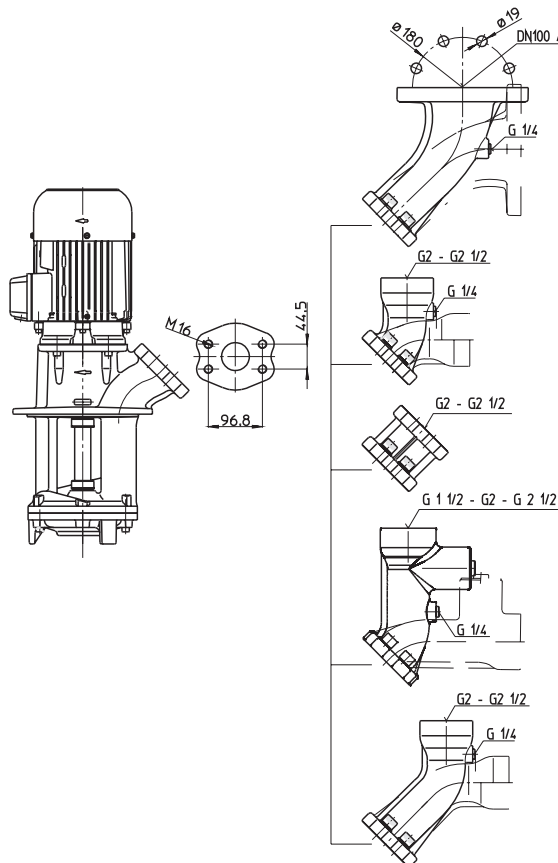

Flange DN100/PN16

This flange is available upon request for all pumps with larger pump body which are featuring a 45 degree flange.

45 degree flange G2, G2 1/2

Standard as shown on data sheets. G 2 is available upon request instead of the G 2 1/2 without surcharge.

Extension Port for 45 degree flange

This extension port is available upon request for all pumps which are featuring a 45 degree flange.

Regulating Valve for 45 degree flange G1 1/2, G2, G2 1/2

This regulating valve allows to adjust the flow rate of the pump even during regular operation. This valve has no complete shut off function.

Extended 45 degree flange G2, G2 1/2

Standard for motors larger than 11 kW and for standard motors.